Installation, Operation and Maintenance Manual

for the
iRSVP Metal Seated Ball Valve
ASME Class 1500 / 3100 / 4500



**PREPARE THE VALVE
FOR INSTALLATION**

**INSTALL THE VALVE
PROPERLY**

**STRESS RELIEVE
WELDS ACCORDING
TO ASME B31.1**

**MAINTAIN THE VALVE FOR
OPTIMAL OPERATION
AND PERFORMANCE**

MOGAS[®]

Important User Information

HOW TO READ THIS MANUAL

All information within this manual is relevant to the safe and proper care of your MOGAS ball valve. The following are examples of instructional information used throughout this manual.

0.00

INSTALL HANDLEVER ADAPTOR

To **install** the handlever adaptor **13**, first remove the hex head bolt **36** that holds the hand lever **53** in place.

Identifies and explains sequential procedure to be performed.

Bold numbers correspond with items shown in the Valve Item Reference Number sections.

Note: The normal direction of flow is from the higher pressure end (upstream) to lower pressure end when the valve is **closed**.

Note provides important information related to a procedure.

SAFETY INFORMATION

It is important to read and follow these safety instructions.



WARNING!

Do not perform this task under line pressure. Make sure the line is **not** under pressure.

Indicates a hazardous situation which, if not avoided, could result in death or serious injury.



CAUTION!

Do not use the MPS as the primary stop if valve is operated by gear or actuator.

Indicates a hazardous situation which, if not avoided, could result in minor or moderate injury.

NOTICE

For installation, the valve must be in **OPEN** position to protect the ball from surface damage.

Indicates a potential situation which could result in damage to the valve or may void the warranty.

Contents

| | |
|--|----|
| RECEIVING AND INSPECTION..... | 4 |
| VALVE INFORMATION..... | 5 |
| VALVE DESIGN | 6 |
| OPERATOR CONFIGURATIONS..... | 7 |
| VALVE ITEM NUMBERS | 8 |
| MANUAL ADAPTION..... | 10 |
| OPERATOR ADAPTION / ACTUATION..... | 12 |
| INSTALLATION | 14 |
| POST WELD HEAT TREATMENT (PWHT) | 16 |
| OPERATION..... | 20 |
| MAINTENANCE..... | 21 |
| REPLACE STEM PACKING..... | 22 |
| REMOVE VALVE FROM SERVICE..... | 26 |
| STORAGE | 26 |
| RETURN MERCHANDISE AUTHORIZATIONS..... | 27 |

Receiving and Inspection

TRANSPORT

Valves are shipped in seaworthy export packed wooden crates that are plastic lined.

REMOVE VALVE

Remove the valve (and operator, if supplied) carefully from the shipping crate or pallet using lifting lugs or nylon straps around the **valve body** and sturdy section of the operator. **Do not** lift by the operator alone.

INSPECT VALVE

Inspect the general condition of the valve (and operator, if supplied) for any potential shipping damage.

Review the valve manual, assembly drawing with the bill of materials, and the operator manual (if supplied) shipped with the valve.

REMOVE PROTECTIVE COVERS

Remove protective covers from ends to inspect valve internally for shipping debris or damage.

Replace protective covers until ready for installation.

Valve Information

INFORMATION LOCATIONS

Valve information is on both sides of the valve body and on the valve tag, located on the side of the integral mounting bracket.

VERIFY SPECIFICATIONS

Verify the valve tag information to confirm the valve is suitable for the intended service.

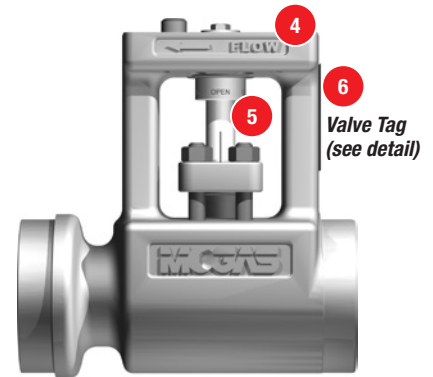
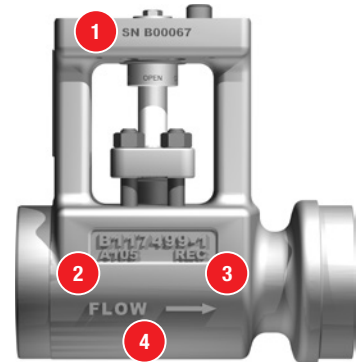

VALVE TAG INFORMATION

1. Serial Number
2. Body Material
3. Heat Code
4. Flow Direction
5. Open/Closed Indicator
6. Max. Pressure Rating
7. Pressure End Identification
8. Model
9. End Type
10. Bore Size
11. Pressure Class
12. Trim Material
 - Stem
 - Ball
 - Seat
13. Year Valve Manufactured (not installed)

Valve Tag Detail

| | | |
|----|---|----------------|
| 6 | MOGAS USA B16.34 LTD | |
| | MAX RATED PRESSURE | |
| | 260 BAR (3750 PSIG) @ 38° C (100° F) | |
| | 177 BAR (2570 PSIG) @ 427° C (800° F) | |
| 7 | HIGH PRESSURE END IN CLOSED POSITION | |
| 8 | MODEL | RSVP-UF 2 A105 |
| | SIZE | DN50 (2") |
| 9 | ENDS | SW |
| 10 | BORE | 25mm (1") |
| 11 | RATING | 260PN (1500#) |
| | STEM | GR 660 |
| 12 | BALL | 410/CC |
| | SEAT | 410/CC |
| 13 | YEAR OF MFG | 2005 |

Valve Design

DESIGN

The iRSVP valve is designed for **on / off** services only.

To operate, turn **counter-clockwise to open** and **clockwise to close**.

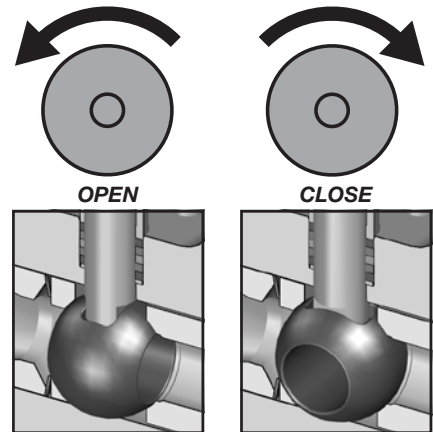

CAUTION!

Throttling with ball valves is **not** recommended. Prolonged exposure of a portion of the ball to flow can compromise the sealing integrity of the valve.

THIS WILL AFFECT THE VALVE WARRANTY.

SEALING DIRECTION

All RSVP valves have a single direction of sealing indicated by a flow arrow on the body. The valve tag is located on the “High Pressure End” of the valve mounting bracket.

Note: In certain conditions, proper operation may require the flow arrow be opposed to the line flow. Make sure that the “High Pressure End” is positioned toward the highest pressure against the valve in the closed position. (Example: A downstream block valve isolating a control valve will have the arrow pointing upstream.)

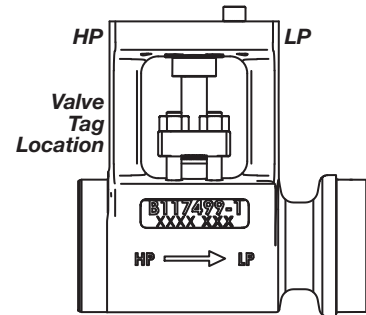

WARNING!

Do not install valve for pressures or temperatures higher than rated.

THIS WILL AFFECT THE VALVE WARRANTY.

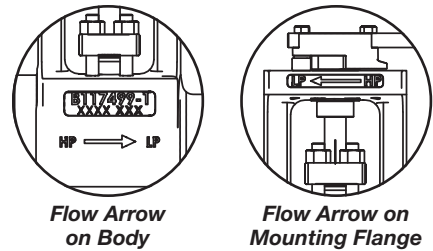

FIELD REPAIR

Replacing stem packing is the only field repair recommended. See section labeled Replacing Stem Packing.

For all other repairs, contact MOGAS Service Department.

Operator Configurations

VERIFY OPERATOR

MOGAS valves may be supplied in a variety of operator configurations based on customer requirements, including:

- manual actuation (handlever)
- worm gear actuation (handwheel)
- hydraulic actuation
- pneumatic actuation
- electric actuation
- stem adaptor kits
- bare stem

Each of these operator configurations may be installed and tested prior to shipping, or shipped separately, depending on customer requirements.

Note the configuration of each individual valve and proceed with any necessary operator adaption procedures **prior** to installing the valve.

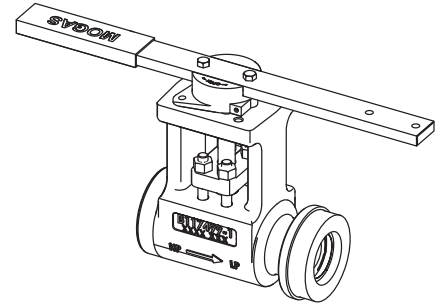

Valve with Handlever Kit

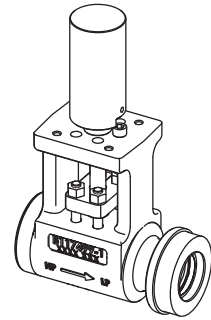

Valve with Blank Stem Adaptor

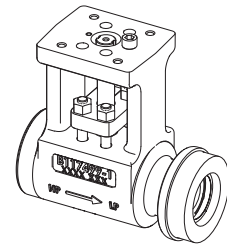

Valve with Bare Stem

Valve Item Numbers

Valve Item Number Reference

| Item | Description | Qty |
|------|--------------------------------------|--------|
| 1A | Ball | 1 |
| 1B | Seat Ring | 1 |
| 1C | Spring Disc | 1 or 2 |
| 1D | Seat Ring Pusher | 1 |
| 02 | Body | 1 |
| 05 | Stem | 1 |
| 7A | Gland Flange | 1 |
| 7B | Thruster, Gland Flange | 1 |
| 7C | Spring Discs (Live Loading) | 2 |
| 9A | Ring, Stem Packing | 2 or 3 |
| 9B | Ring, Anti-Extrusion | 1 |
| 9C | Ring, Anti-Extrusion (Metal) | 1 |
| 12 | Stud, Gland | 4 |
| 15 | Nut, Gland | 4 |
| 16 | Bushing, Stem | 1 |
| 17 | Pin | 1 |
| 28 | Retainer Ring, External Self-locking | 1 |
| 29 | Transition Sleeve | 1 |
| 42 | Mechanical Precision Stop | 1 |
| 84 | Socket Weld Spacer Ring | 2 |

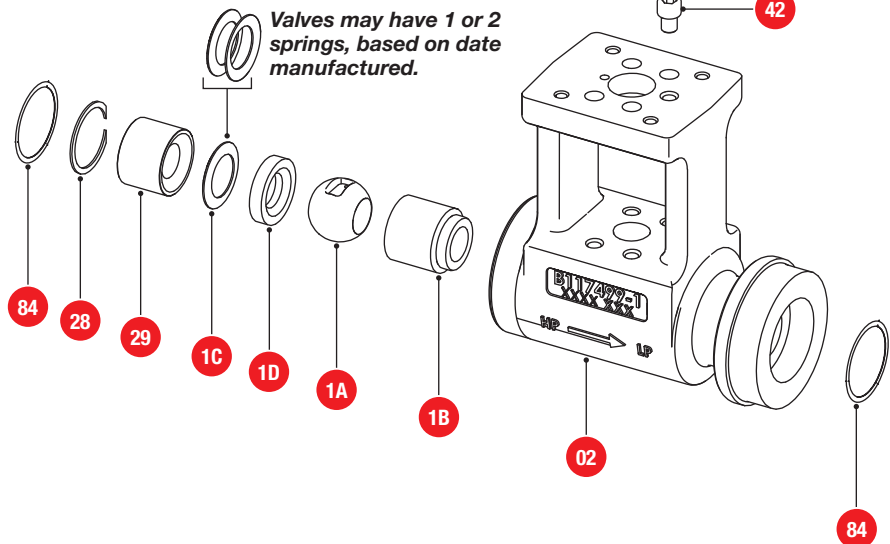
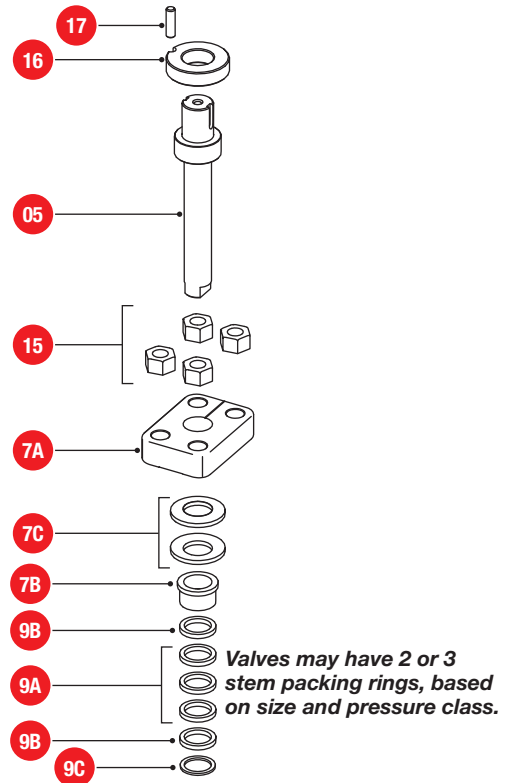

Note: Contact MOGAS or a MOGAS Authorized Repair Center to determine the spare parts and quantities required for your specific circumstance.

Handlever Kit Item Numbers

| Valve Item Number Reference | | |
|-----------------------------|--------------------|-----|
| Item | Description | Qty |
| 06 | Key | 2 |
| 7D | Spring | 1 |
| 13 | Adaptor, Handlever | 1 |
| 18 | Bolt, Hex Head | 1 |
| 26 | Retainer | 1 |
| 35 | Set Screw | 2 |
| 36 | Bolt, Hex Head | 2 |
| 53 | Handlever | 1 |
| 53A | Hand Grip | 1 |
| 58 | Retainer Bushing | 1 |

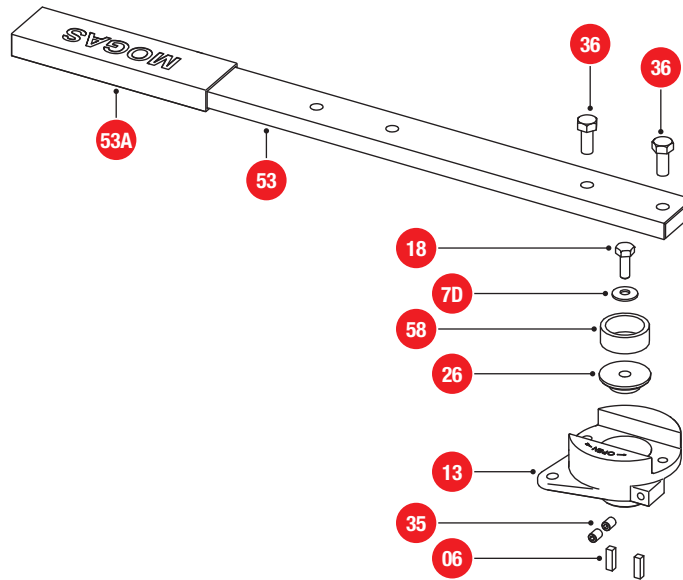

Blank Stem Adapter Kit Item Numbers

| Valve Item Number Reference | | |
|-----------------------------|--------------------|-----|
| Item | Description | Qty |
| 06 | Key | 2 |
| 13 | Blank Stem Adaptor | 1 |

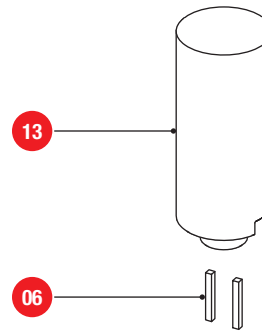

Manual Adaption

1 INSTALL HANDLEVER ADAPTOR

Install two keys **06** into stem slots of handlever adaptor **13**, using grease to hold them in place.

Fit handlever adaptor **13** onto stem **05**, engaging keys.

Install retainer **26** and retainer bushing **58**, securing with spring **7D** and hex head bolt **18**.

Torque per the specifications included with the **test certificate** for each individual valve serial number.

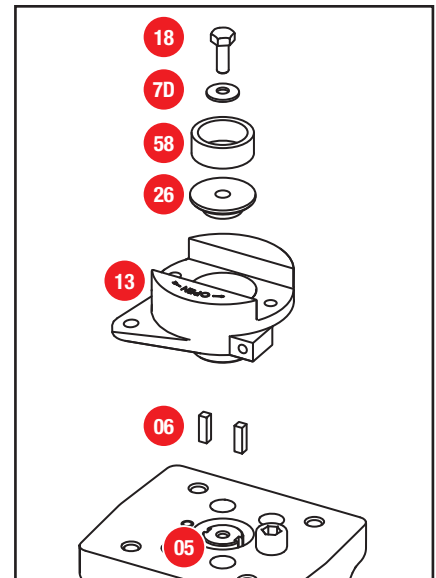

2 POSITION HANDLEVER

Position the handlever **53** in the desired location.

Note: The handlever can be arranged in any of three positions (as typical extended handle, reverse extended handle or T-handle) to accomodate required clearance.

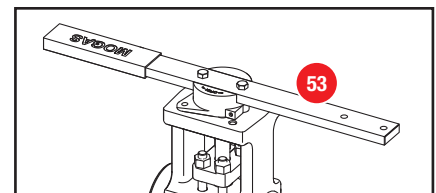
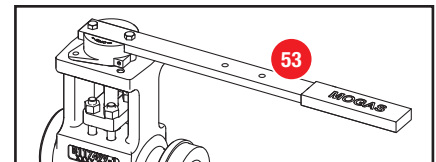
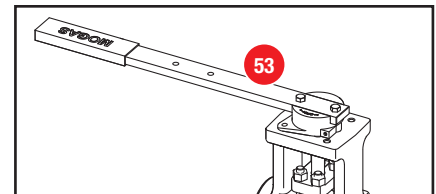

3 SECURE HANDLEVER IN PLACE

Secure handlever **53** in place using two hex head bolts **36**.

Torque per the specifications included with the **test certificate** for each individual valve serial number.

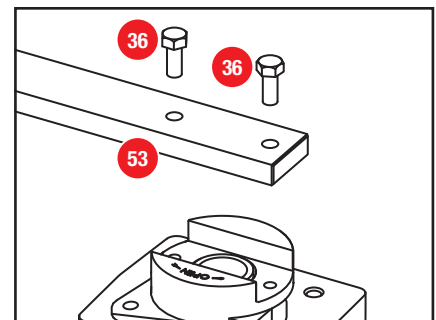

Manual Adaption

4 VERIFY OPERATING POSITION

The **fully open** position is the most important position to set. It is preferred that the **open** position be set while the valve is not installed in the pipeline. This allows for the bore to be properly aligned, ensuring that no edges are exposed to the flow.

Looking through the bore, verify that the ball is perfectly aligned in the **fully open** position.

Check the **OPEN** marking at the top of the stem. The vertical marking **A** on the stem should align with the marking **B** on the gland flange. The vertical marking **A** on the stem should align with the marking **B** on the gland flange. These lines are approximate indications. For best results, make sure the lines never under travel — a minimum travel of 96° is required.

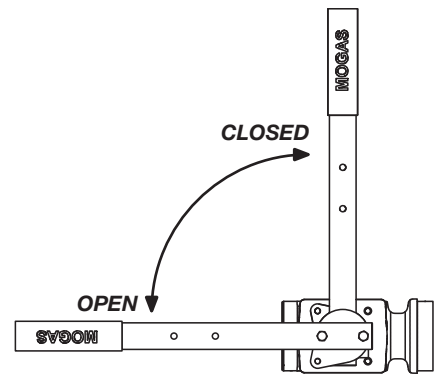
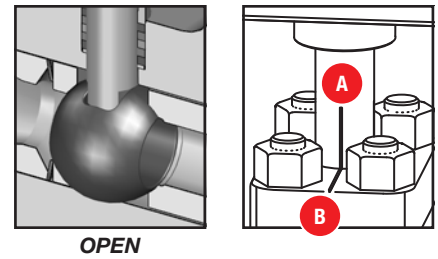

CAUTION!

Misalignment of actuation stops can result in valve under or over stroke, creating a potential leak path.

THIS WILL AFFECT THE VALVE WARRANTY.

5 SECURE OPERATING POSITION

The mechanical precision stop (MPS) **42** is used to locate the **open/closed** position of the valve as contact is made from the adaptor.

Precision adjustments are made with the two set screws **35**, located in the adaptor.

When the ball is perfectly aligned in the **open** position, remove the locking set screw and tighten the adjusting set screw against the mechanical precision stop (MPS). Secure this position with the locking set screw.

Lock-out devices may be used in the holes provided to secure **open/closed** positions.

Note: The valve is now ready for installation.

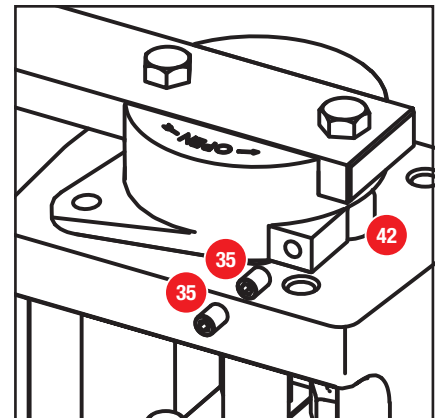

Operator Adaption / Actuation

STEM ADAPTOR

When the actuation package is provided by MOGAS, the stem adaptor **13** will already be machined to fit the actuator.

Per customer requirements, the stem adaptor **13** may be furnished blank, so it can be machined to engage a variety of electric, pneumatic or worm gear actuators.

Note: Refer to the manufacturer's manual for specific operator/actuator installation details.

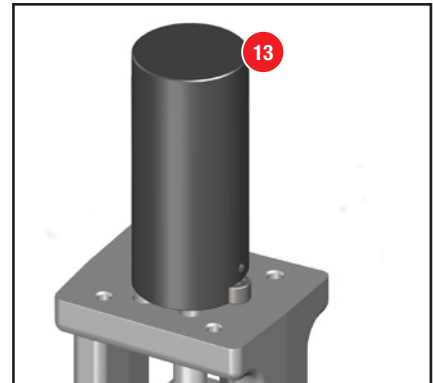

1 INSTALL THE OPERATOR

Following the operator manufacturer's instructions, orient the operator to the desired position and secure to the mounting flange.

2 LOCATE OPEN POSITION

The **fully open** position is the most important position to set. It is preferred that the **open** position be set while the valve is not installed in the pipeline. This allows for the bore to be properly aligned, ensuring that no edges are exposed to the flow.

Using a reduced torque actuator setting (electric) or regulated air pressure (pneumatic), turn or activate the operator counter-clockwise until the stem adaptor **13** contacts the mechanical precision stop (MPS) **42**. This will indicate the **open** position of the valve.

Looking through the bore, verify that the ball is perfectly aligned in the fully **open** position. Check the **OPEN** marking at the top of the stem. The vertical marking **A** on the stem should align with the marking **B** on the gland flange. These lines are approximate indications. For best results, make sure the lines never under travel — a minimum travel of 96° is required.

Adjust stop/limit switches or operator to set the **open** position.

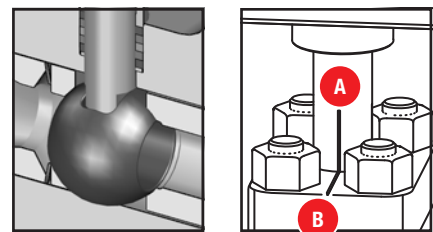
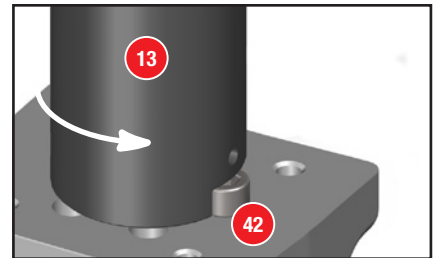

CAUTION!

Misalignment of actuation stops can result in valve under or over stroke, creating a potential leak path.

THIS WILL AFFECT THE VALVE WARRANTY.

Operator Adaption / Actuation

3 LOCATE CLOSED POSITION

Using a reduced torque actuator setting (electric) or regulated air pressure (pneumatic), turn or activate the operator clockwise until the stem adaptor **13** contacts the mechanical precision stop (MPS) **42**. This will indicate the **closed** position of the valve.

Verify operating position by checking the **CLOSED** marking at the top of the stem. The vertical marking **A** on the stem should align with the marking **B** on the gland flange. These lines are approximate indications. For best results, make sure the lines never under travel — a minimum travel of 96° is required.

Adjust stop/limit switches or operator to set the **closed** position.

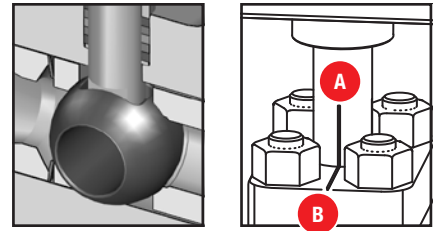
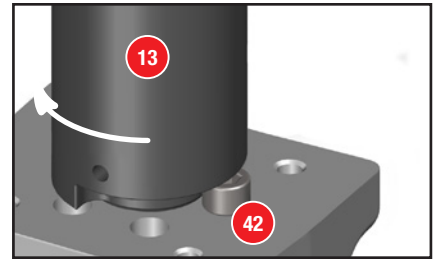

CAUTION!

Do not use the MPS as the primary stop if valve is operated by gear or actuator.

4 SET STOPS

Actuator/gear factory set stops should be adjusted to the position of the valve stops.

When both stops (or limit switches) are set, turn each stop approximately a quarter turn to ensure that the open and close positions of the valve will contact the operator stops, **not** the mechanical precision stop (MPS).

The operator/actuator can now be set to the full operating torque according to the manufacturer's guidelines.



CAUTION!

Misalignment of actuation stops can result in valve under or over stroke, creating a potential leak path.

THIS WILL AFFECT THE VALVE WARRANTY.

Note: The valve is now ready for installation.

Installation

1 PREPARE VALVE ENDS

Note: All procedures shown are for socket weld ends.

SOCKET WELD ENDS

Remove the blue plastic protective covers that were placed on valve ends at the factory.

Do not remove contraction rings **84** from inside socket weld valves. Rings position pipe to protect the weld during thermal expansion.

BLANK BUTT WELD ENDS (OPTIONAL)

Blank butt weld ends (if ordered) will need to be machined prior to installation.

The welding end detail preparation is based on **ASME B16.34** and **ASME B16.25**. To achieve the full valve body pressure rating, the inside diameter of the welding ends are to be followed by the pipe size listed under **ASME B16.34 Annex A**.

Do not allow any debris to get into the valve. Leave the factory supplied plug in place to protect the valve opening during machining.

Machine to the desired configuration. After machining, thoroughly clean the bore area and remove the plug.

2 VERIFY BALL POSITION

While looking in the bore, open and close the valve. Verify that the ball position **matches** the handle position or actuator indicator.

NOTICE

For installation, the valve must be in **OPEN** position to protect the ball from surface damage.

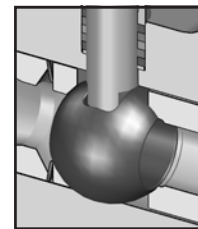

OPEN

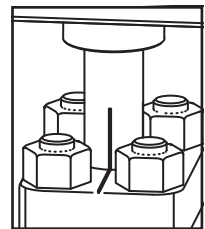

INDICATOR

Installation

3 POSITION VALVE IN PIPING

Position the valve in piping for the required sealing direction.

NOTICE

Support or lift as required, using lifting lugs or nylon straps around the valve body. **Do not** lift or support by the actuator alone.

All RSVP valves have a single direction of sealing indicated by a flow arrow on the body. The valve tag is located on the “High Pressure End” of the valve mounting bracket.

Note: In certain conditions, proper operation may require the flow arrow be opposed to the line flow. Make sure that the “High Pressure End” is positioned toward the highest pressure against the valve in the closed position. (Example: A downstream block valve isolating a control valve will have the arrow pointing upstream.)

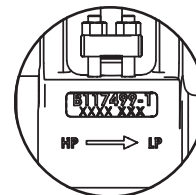
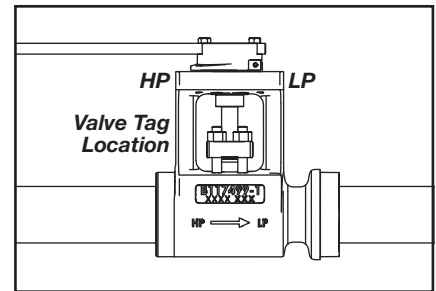

Flow Arrow on Body

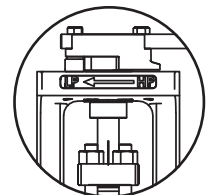

Flow Arrow on Mounting Flange



CAUTION!

Before welding, valve **must** be in the **OPEN** position to protect the ball from weld splatter and surface damage.

Do not allow the main valve body to reach a temperature hotter than 1100° F (593° C) during installation, welding or post weld heat treatment.

THIS WILL AFFECT THE VALVE WARRANTY.

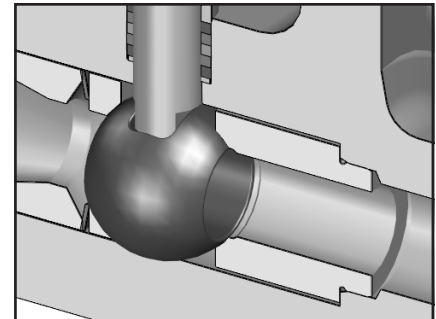

4 WELD VALVE IN PLACE

Weld valve in place according to **ASME B31.1** or **ASME B31.3** requirements.

NOTICE

Always attach the welding ground strap to the **same end** being welded

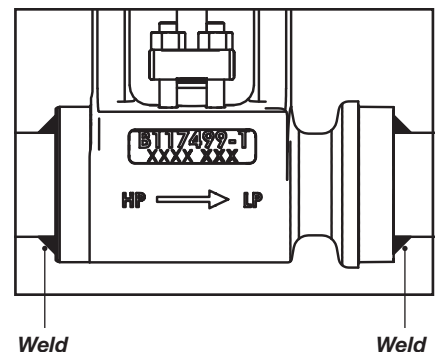

Post Weld Heat Treatment (PWHT)

Note: PWHT may not be required for all valves. Consult ASME B31.1 to determine whether PWHT is required.

1 INSTALL HEATING BLANKETS

Before heat treatment, install heating blankets as shown in the following section “PROPER PWHT INSTALLATION.”

Do not install heating blankets to the center section of the valve body (indicated by the dotted red outline), including the neck section of the vented area.

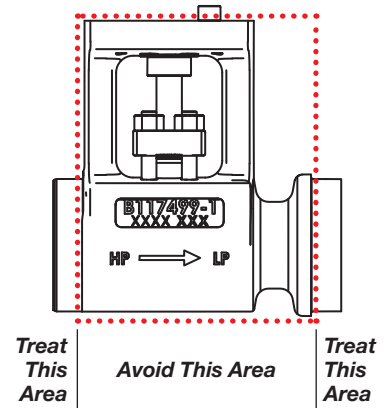

CAUTION!

The valve body **must** always remain below 1100° F (593° C). Proper use and placement of heating blankets accomplish this.

THIS WILL AFFECT THE VALVE WARRANTY.

PROPER PWHT INSTALLATION

Install heating blankets, covered by proper insulation, as shown — **no gaps/no overlaps**. Heating blankets cover only weld areas. Blankets **should not cover** any part of the center section of the valve body.

This will allow the **best** and **most effective** stress relieving in accordance with ASME B31.1, while **protecting** the ball and seat assembly from damage.

If using a “snake” (sinuous coil heating element), make sure both ends of the valve are heated uniformly. An uninsulated loop in the middle will prevent proper heating. There are 4 possible solutions:

1. Insulate the loop only.
2. Use two separate snakes, one for each end.
3. Treat each end separately.
4. Avoid snakes. Best results are obtained with snug-fitting blankets, properly placed and insulated.

Note: Improper installations of heating blankets are shown in the following section.

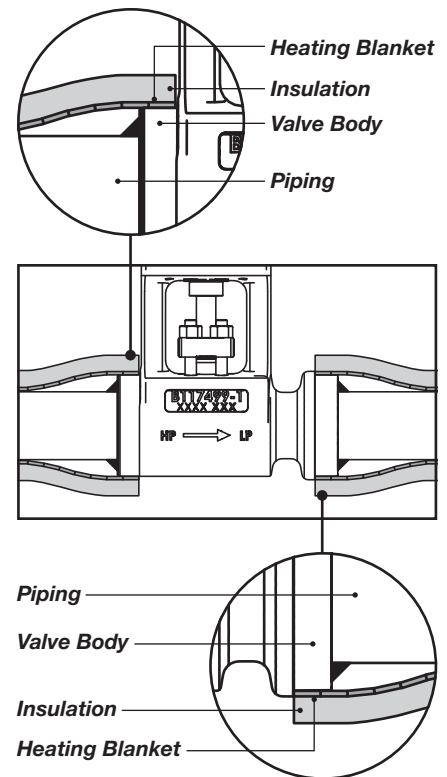

Post Weld Heat Treatment (PWHT)



IMPROPER PWHT INSTALLATION

Heating blanket is not installed properly.

Heating blanket needs to cover the machined outside diameter of the socketweld, as well as the weld and pipe areas, to provide enough heat for proper stress relief.

Insufficient stress relief may result in damage, delay, and increased costs.

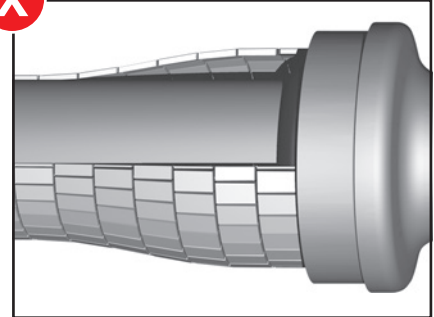

Heating blanket is too long.

When a single heating blanket is too long and is “tucked in” at the end, heating elements next to the pipe can easily be **damaged** by heat from the elements on top of them.

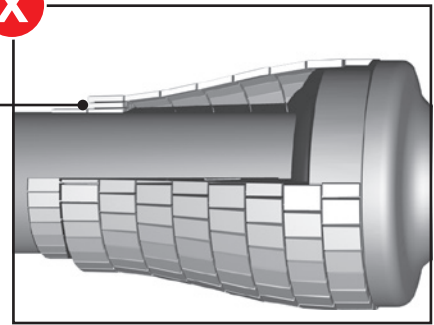
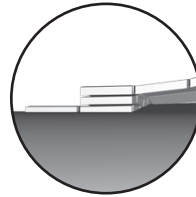

Heating blanket is applied to valve body.

The use of three heating blankets is definitely **not** how to do it. **Never** apply heat to the valve body. The center section of the valve body **must** remain uninsulated and unheated.

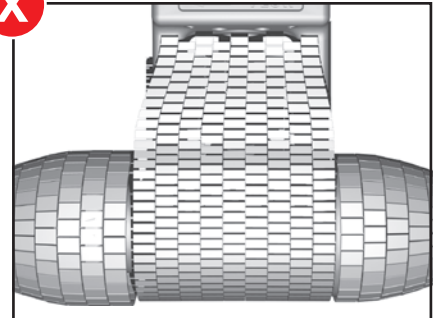

Post Weld Heat Treatment (PWHT)

2 STRESS RELIEVE THE WELDS

See guidelines for stress relief in ASME B31.1. PWHT temperatures are shown below.

Note: These guidelines may be substituted by customer's special requirements or best-practice procedures.

PWHT Requirements per ASME B31.1 and B31.3

| Material | Part Number | Group Number | Preheat ° F (° C) | Holding Temp. Range ° F (° C) | Holding Time based on Nominal Thickness | |
|-----------------------|-------------|--------------|-------------------|-------------------------------|--|--|
| | | | | | Up to 2 inches (50 mm) | Over 2 inches (50 mm) |
| A105 ¹ | 1 | 1,2,3 | 200 (95) | 1100 – 1200 (600 – 650) | 1 hour / inch (25 mm); 15 minutes minimum | 2 hours; Plus 15 minutes for each additional inch over 2 inches (50 mm) |
| A182-F22 ² | 5A | 1 | 300 (150) | 1300 – 1400 (700 – 760) | | |
| A182-F91 A182-F92 | 5B | 1,2 | — | 1350 – 1375 (732 – 746) | | |

PWHT Notes:

¹ PWHT is not mandatory provided the nominal thickness is 0.75 inches (19 mm) or less and the minimum preheat temperature is applied when the nominal material thickness of either of the base metals exceeds 1 inch (25.4 mm).

² PWHT is not mandatory provided the NPS is 4 or less, nominal material thickness is 0.5 inches (12.7 mm) or less, a specified carbon content of the material to be welded is 0.15% or less, and the minimum preheat temperature is maintained during welding.

3 VERIFY OPERATION

After installation, open and close the valve to ensure smooth operation.

To operate, turn **counter-clockwise to open** and **clockwise to close**.

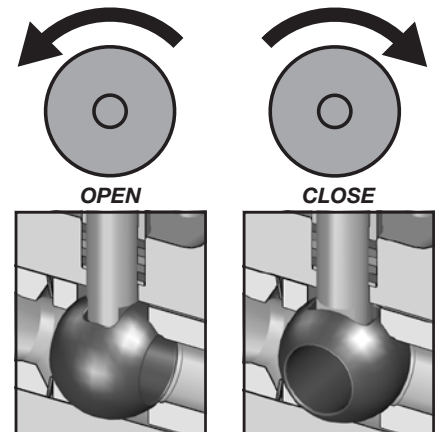

Post Weld Heat Treatment (PWHT)

4 VALVE INSULATION

Insulate valve as needed.

Valve insulation should **not** extend above the bottom of the valve tag, to ensure visibility of valve information at all times.

This is approximately the bottom of the packing gland flange, as shown by the dotted red line in the illustration.

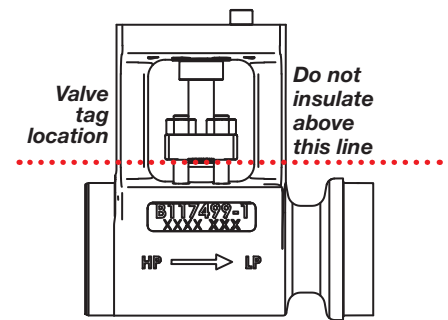

Operation

NOTICE

Due to the potential for packing consolidation, verify proper packing torque adjustment prior to placing the valve in service.

1 OPEN / CLOSE

The iRSVP valve is designed for **on / off** services only.

To operate, turn **counter-clockwise to open** and **clockwise to close**.

Note: When cycling the valve **open** or **close**, make sure that the valve is **fully opened** and **fully closed**. This wipes debris from the ball and ensures optimal performance and long valve life.

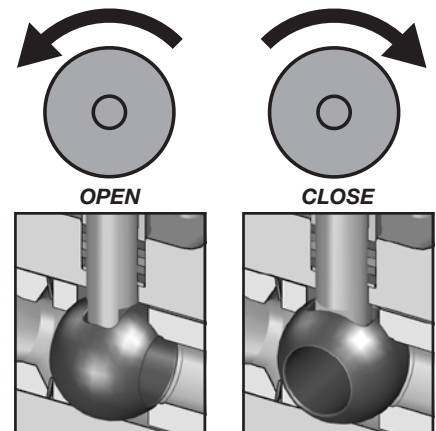

CAUTION!

Throttling with ball valves is **not** recommended. Prolonged exposure of a portion of the ball to flow can compromise the sealing integrity of the valve.

THIS WILL AFFECT THE VALVE WARRANTY.

1 RE-TORQUE PACKING GLAND

After the first exposure to elevated temperature, re-torque the valve's packing gland.

Check packing gland nuts periodically, and re-torque if necessary.

The following table shows the proper torque required.

| Recommended Packing Gland Stud Torque – ft. lbs. (N m) | | | |
|--|-----------------|-----------------|-----------------|
| Valve Bore | ASME 1500 Class | ASME 3100 Class | ASME 4500 Class |
| 0.63 inches (16 mm) | 4 (5.4) | 11 (14.9) | 16 (21.7) |
| 1.00 inches (25 mm) | 7 (9.5) | 15 (20.3) | 25 (33.9) |
| 1.3 inches (33 mm) | 8 (10.8) | 17 (20.0) | — |
| 1.5 inches (38 mm) | 9 (12.2) | — | — |

2 OPEN / CLOSE VALVE REGULARLY

Valves remaining **open** or **closed** for a long period of time should be cycled **open / closed** at least once a year.

Valves should always be **fully opened** and **fully closed** to wipe away any accumulation on the sealing surfaces.

3 ACTUATOR LUBRICATION

Keep manual actuators fully lubricated with extreme pressure and/or high-temperature grease as applicable.

Keep hydraulic, pneumatic and worm gear actuators fully lubricated according to actuator manufacturer's specifications.

NOTICE

Avoid valve lubrication. MOGAS ball valves **do not** need lubrication.

INJECTION OR IMPROPER USE OF A LUBRICANT MAY VOID THE WARRANTY.

Replace Stem Packing



WARNING!

Do not perform this task under line pressure. Make sure the line is **not** under pressure.

- 1 Locate packing gland nuts **15**. Turn nuts counter clockwise to loosen and remove packing gland nuts.

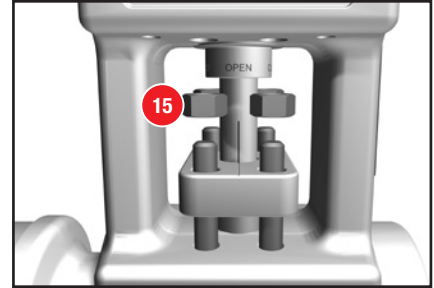

- 2 Remove studs **12** to allow access to the used packing rings.

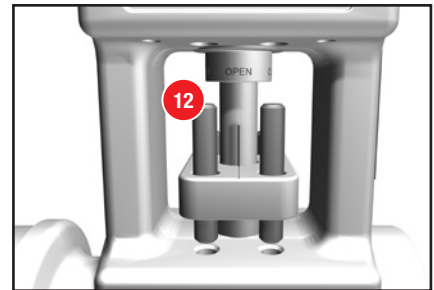

- 3 Locate and slide upward the gland flange **7A**, live-loading springs **7C** and gland thruster **7B**.

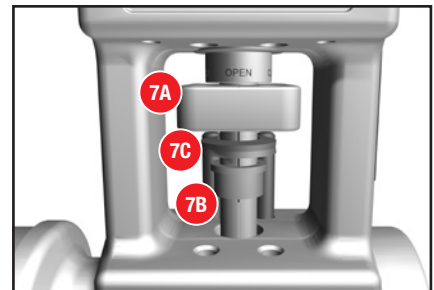

- 4 Using a small pick, carefully remove the packing rings **9A**.
The solid metal anti-extrusion ring **9C** at the bottom of the packing box should **not** be removed.

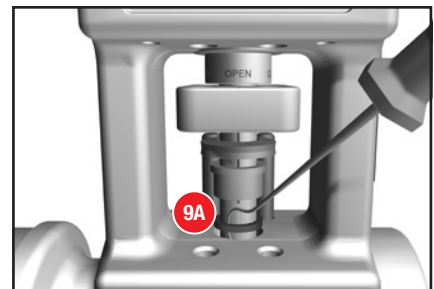

Replace Stem Packing

- 5 Use an air hose to clean debris from packing box before installing new packing rings.



CAUTION!

Always wear a face shield or mono-goggles to protect eyes from flying debris.

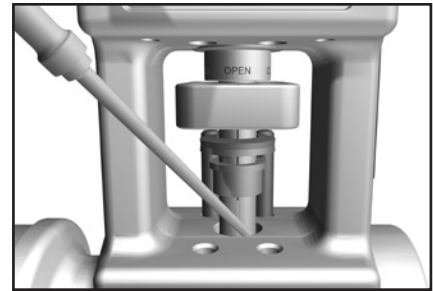

- 6 The new packing ring set will contain 2 anti-extrusion rings **9B**, and 2 or 3 packing rings **9A**. (Refer to the table below to verify the correct packing ring quantity.)

These rings are supplied with a skive cut. Assemble the rings as shown. Position the skive cut on each ring opposite, alternating the adjacent skive cut rings. All rings should fit into the packing box.

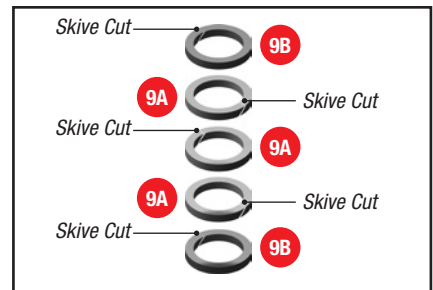

Quantity of Valve Packing Rings

| Valve Bore | ASME 1500 Class | ASME 3100 Class | ASME 4500 Class |
|---------------------|-----------------|-----------------|-----------------|
| 0.63 inches (16 mm) | 2 | 3 | 3 |
| 1.00 inches (25 mm) | 3 | 3 | 3 |
| 1.3 inches (33 mm) | 3 | 3 | — |
| 1.5 inches (38 mm) | 3 | — | — |

- 7 Carefully bend each fragile packing ring **9A**, spiraling it around the stem **05**, then insert and evenly press into the packing box.

Do not try to open ring wide enough to install the ring from the front. Instead, snake it around the stem, minimizing how wide it must be opened. Forcing the ring onto the stem frontally usually causes the ring to break.

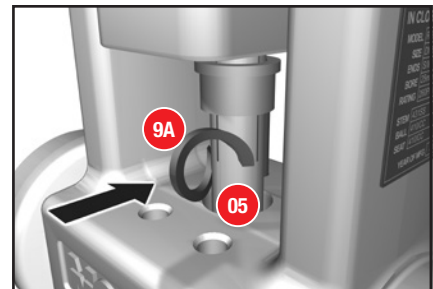

- 8 Use gland thruster **7B** as tool to slide each ring into packing box. Continue this process until all rings are positioned correctly in the packing box.

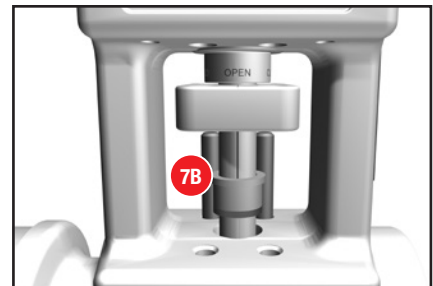

Replace Stem Packing

- 9 Slide the gland thruster **7B** over the packing box.

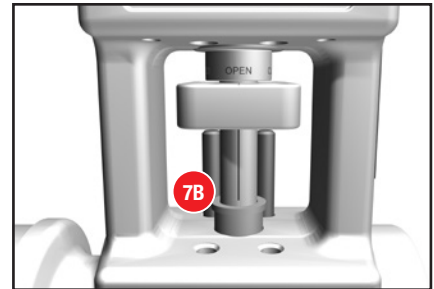

- 10 Position the live load springs **7C** on top of the gland thruster **7B**.

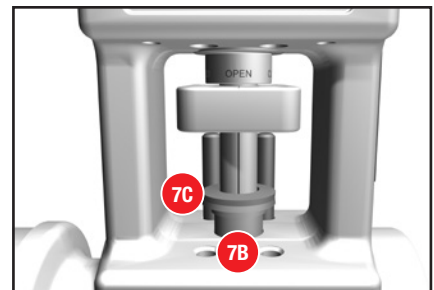

- 11 Re-install the studs **12**.



- 12 Re-install the gland flange **7A** over the packing bolting.

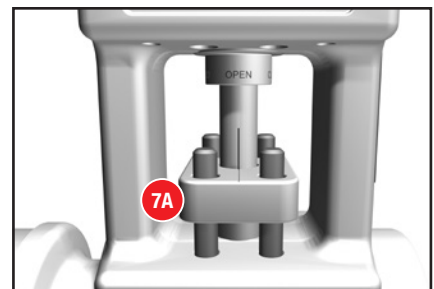

Replace Stem Packing

- 13** Install and tighten nuts **15** evenly by alternating sides when tightening. Make sure the gland flange **7A** does not bind or drag on the stem **05**.

Tighten nuts to the proper torque per table below.

| Recommended Packing Gland Stud Torque – ft. lbs. (N m) | | | |
|--|-----------------|-----------------|-----------------|
| Valve Bore | ASME 1500 Class | ASME 3100 Class | ASME 4500 Class |
| 0.63 inches (16 mm) | 4 (5.4) | 11 (14.9) | 16 (21.7) |
| 1.00 inches (25 mm) | 7 (9.5) | 15 (20.3) | 25 (33.9) |
| 1.3 inches (33 mm) | 8 (10.8) | 17 (20.0) | — |
| 1.5 inches (38 mm) | 9 (12.2) | — | — |

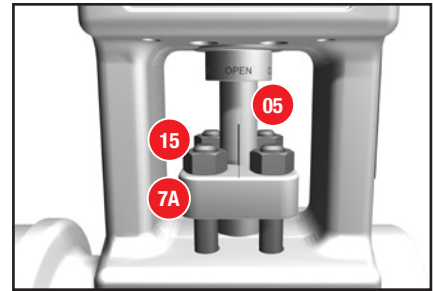

- 14** Cycle valve several times to ensure proper re-packing.

NOTICE

Due to the potential for packing consolidation, verify proper packing torque adjustment prior to placing the valve in service.

After the first exposure to elevated temperature, re-torque the valve's packing gland.

Check packing gland nuts periodically, and re-torque if necessary.

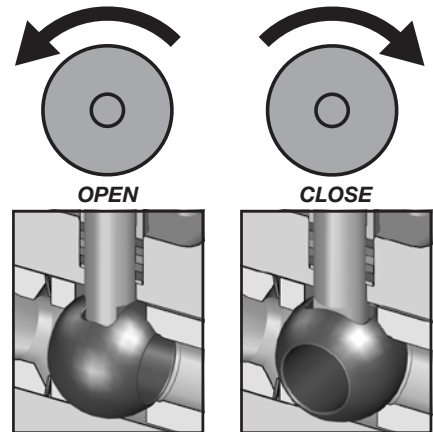

Note: These procedures outline the general requirements for storage of MOGAS valves.

SHORT-TERM STORAGE

MOGAS valves are shipped in seaworthy export packed wooden crates that are plastic lined. For short-term storage, valves shall remain stored in their shipping crates, or on their pallets, with the lids secured.

Valves are shipped with corrosion-resistant paint and desiccant dries (dryer bags) for storage up to six months.

All protective covers and plastic liners should remain in place.

REMOVING VALVE FROM SERVICE

Before the valve is removed from the line, it should be placed in the **open** position to prevent further internal damage to valve components.

Once removed, the valve should be placed in a vertical position, or raised at an angle. The bore of the valve should be either steamed cleaned or power washed to remove slurry and debris.

The valve should be allowed to drain and dry. A petroleum-based rust inhibitor should be applied through the bore of the valve immediately after the valve is dry.

LONG-TERM STORAGE

For long-term storage, the internal parts of carbon and alloy steel valves should be sprayed with a rust preventative.

Bore protectors need to be secured to each end of the valve to prevent any foreign debris from entering the valve. It is recommended to place desiccant dryer bags inside the valve before storage.

The valve should be stored in the vertical position, out of the weather (inside), until repairs can be made.

Return Merchandise Authorizations (RMA)

All valve or valve parts that are **returned** require a Return Merchandise Authorization (RMA).

Please have the following information available prior to submitting an RMA request:

- Serial number
- Valve owner
- Application specifics (where the valve is used)
- Media (what goes through the valve)
- Total estimated cycles (from last installation)
- Operating temperature (max. F)
- Operating pressure (max. PSI)
- Actuator specifics

Contact the MOGAS Service department to obtain authorization and to receive shipping instructions. The RMA request may also be submitted online by accessing the **Service** page of our website (www.mogas.com).

Service Contact

MOGAS Service may be reached
24 hours per day / 7 days per week.

Telephone: **+1 281.449.0291**

Email: **service@mogas.com**

Severe Service

The MOGAS Definition

- Extreme temperatures
- High pressures
- Abrasive particulates
- Acidic products
- Heavy solids build-up
- Critical plant safety
- Large pressure differentials
- Velocity control
- Noise control

MOGAS INDUSTRIES, INC.

Headquarters

14204 East Hardy Road
Houston, TX, USA 77039-1405
Phone: +1.281.449.0291
Fax: +1.281.590.3412
E-mail: mogas@mogas.com

AUSTRALIA

Phone: +61 (0)8.9456.3533

CANADA

Phone: +1 780.436.4485

CHINA

Phone: +86 (0)10.8454.9478

EUROPE

Phone: +44 (0)1162.793367

MIDDLE EAST

Phone: +971 (0)4.889.5667

To locate a sales and
service center in your
area, visit us online at
www.mogas.com.

